

INSERT
COIN

ROUND 1:
FIGHT!



AI in Industry with Entelelect

SACAIR 2023

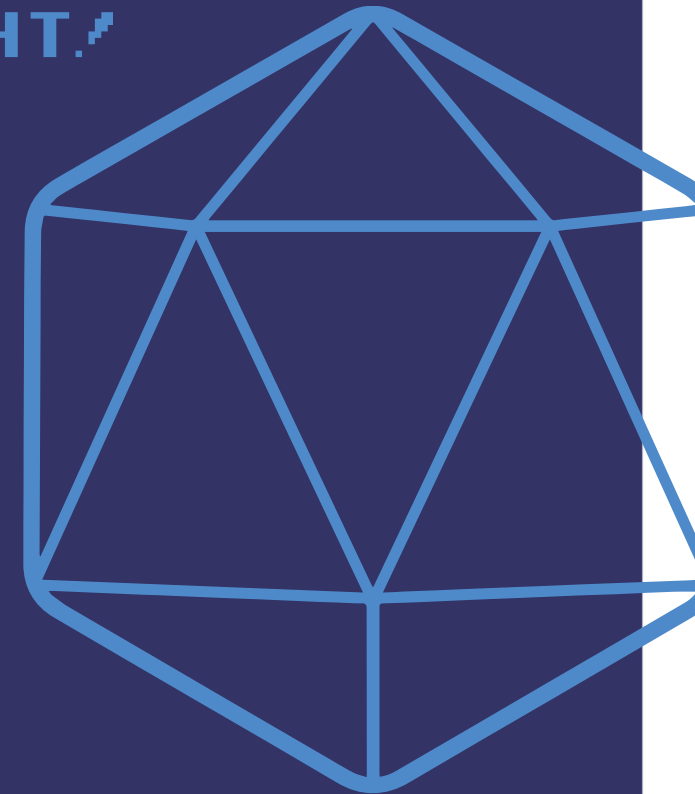

“A LONG TIME AGO
IN A GALAXY FAR,
FAR AWAY...”



>HELLO, WORLD!_

“TAKE THIS -
IT'S DANGEROUS
TO GO ALONE”

“IN A HOLE IN THE GROUND
THERE LIVED A HOBBIT”

Agenda

- About Entelect
- Some of our projects
- How we do data solutions
- Hackathon challenge



WELCOME

Who are we?

We are a company that proves that software development is not synonymous with non-delivery. We prove that it is possible to have a great culture without sacrificing delivery and customer satisfaction. We can be both successful and do good for people.

This is a model we believe in and believe can be applied anywhere in the world. This is what we are working towards.



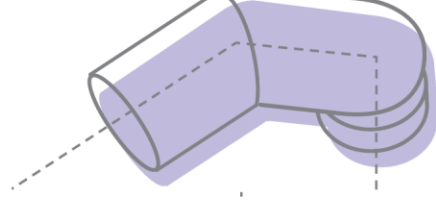
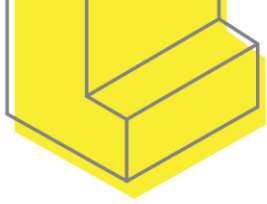
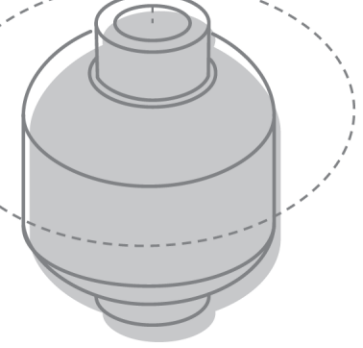

The nuts and bolts

ENTELECT

- People company who build great software
- Founded in 2001
- Run by software engineers
- Over 1500 Entelectuals, 90% of which are software engineers, analysts, data scientists and UX Engineers
- Locations: **Johannesburg, Centurion, Cape Town, Durban, New Zealand, The Netherlands, UK and Australia as well as Zimbabwe.**
- Financial Times – ranked as Africa’s fastest growing company May 2022 and 2023

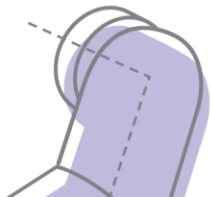
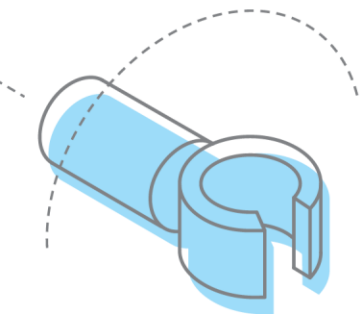
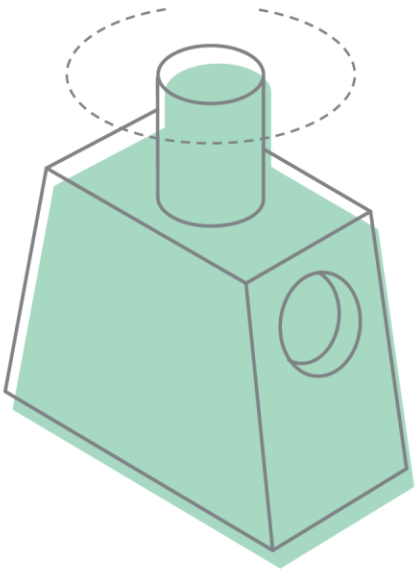



ALLAN GRAY



ASSUPOL



DE BEERS GROUP

Deloitte.



Europcar



Hollard.



LUNO



RGGA



sage BEE123



SANBS
South African National Blood Service



STANLIB



Telkom



Vitality





Tech focused!

And involved with the community

- Hackathons
- Beer and Techs
- Coding Dojos
- Entelect Challenge Main
- Entelect Challenge University Cup
- Tech Accelerator
- DevDays
- Meetups
- Conferences
- Forums



Our Tech



our code

become more

THIS IS OUR CODE, THESE ARE OUR VALUES. USE IT TO JOURNEY INTO THE UNKNOWN, EMBRACE THE FELLOWSHIP IT BRINGS AND REACH BEYOND THE STARS. LET IT GUIDE YOU TO ACHIEVE MORE AND DO THE IMPOSSIBLE. AND IF YOU'RE READING THIS, WE'VE SENSED THE FORCE IS WITH YOU. SO, LIVE BY OUR CODE, YOU MUST AND MORE YOU WILL BECOME.



**TO
BOLDLY
GROW**

GROWTH ISN'T OPTIONAL

- Continually improve and grow
- Learn, teach and assist to grow yourself and others



**fellowship
SETS US APART**

RELATIONSHIPS & COLLABORATION SET US APART

- Maintain a positive team and family spirit
- Partner with our customers
- Show honesty, take responsibility, be courageous, and always have fun

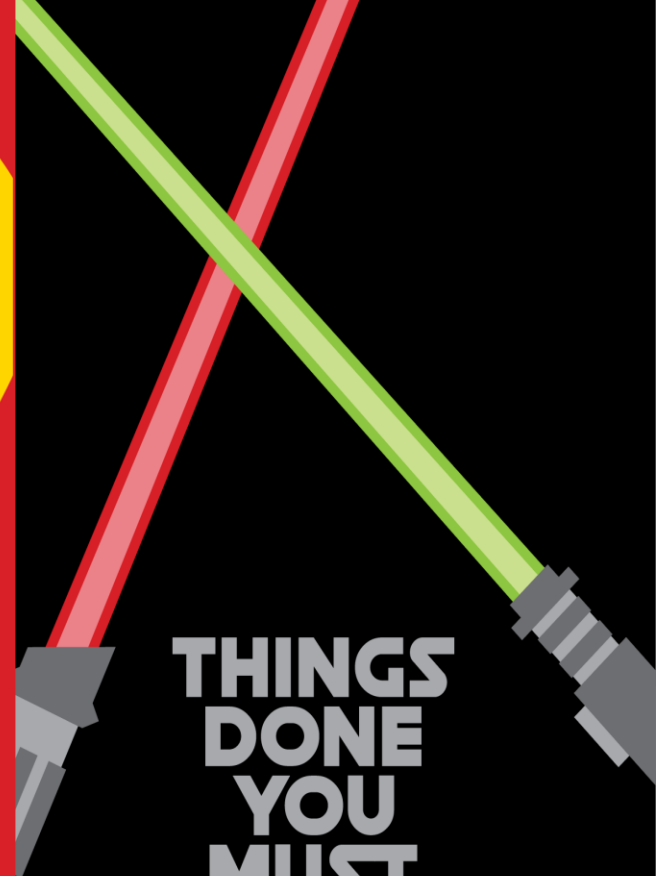

**THINGS
DONE
YOU
MUST
GET**

GET THINGS DONE

- Deliver results that make an impact
- Deliver solutions and excellent service
- Take ownership of delivery and show professionalism and urgency

Our Culture

Live by our code

1. High performance
2. Relationships are key
3. Growth and continuous improvement
4. Autonomous teams
5. Work hard, play harder (social clubs)



**Some of
our
projects**

Some of Our Projects



Developed solutions for a mining company related to integrating data and analytics into software applications that support key business objectives in a meaningful way



Building loyalty platforms designed to drive consumer behaviour and help improve the health and wellness of South Africans



Consolidation of over 50 data sources to provide a single view of a customer, stored within a best practice architected data warehouse



Detect suspicious and fraudulent crossborder financial transactions.

Some of Our Projects



Developing software for a surgical skill simulation portal that measures surgical skill proficiency; enabling trainee surgeons to practice, track and measure their skills remotely.



Developed a real-time behavioural analytics environment and data workflow using Kafka, Storm, Spark, Phoenix and HBase on large volumes of data for spend analysis.



Implemented a cash handling optimization algorithm that resulted in the client saving millions on cash in transit and cash holding costs.

The data science behind driver behaviour

Insure Telematics Solutions (ITS), a leading UK-based provider of telematics devices and systems for automotive insurance, partnered with Entelect to develop a data strategy that could support their increasing data needs and give them access to the data in a way that would allow them to tackle new business opportunities and challenges.

Entelect assisted with designing and building a new architecture for ITS's IoT solution, with a view towards how new technology will allow them to continue scaling.



Using OpenAI to power Entelect's very own EntelliGuide application

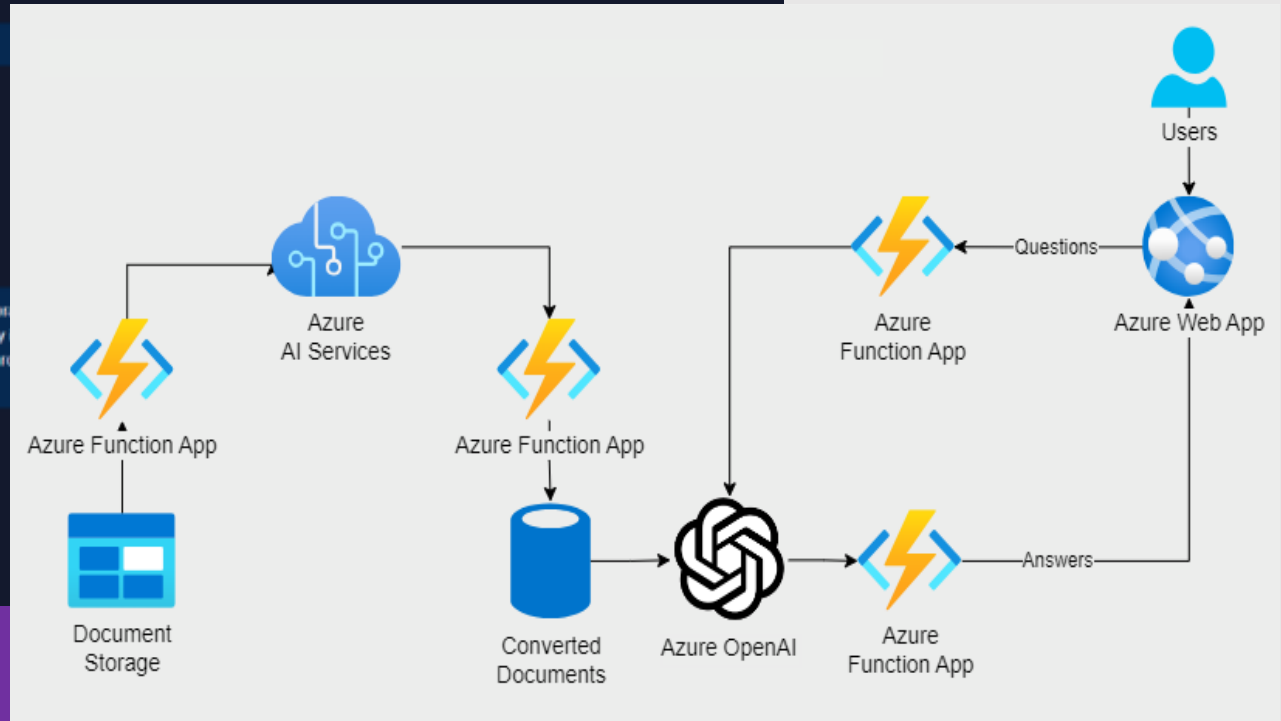
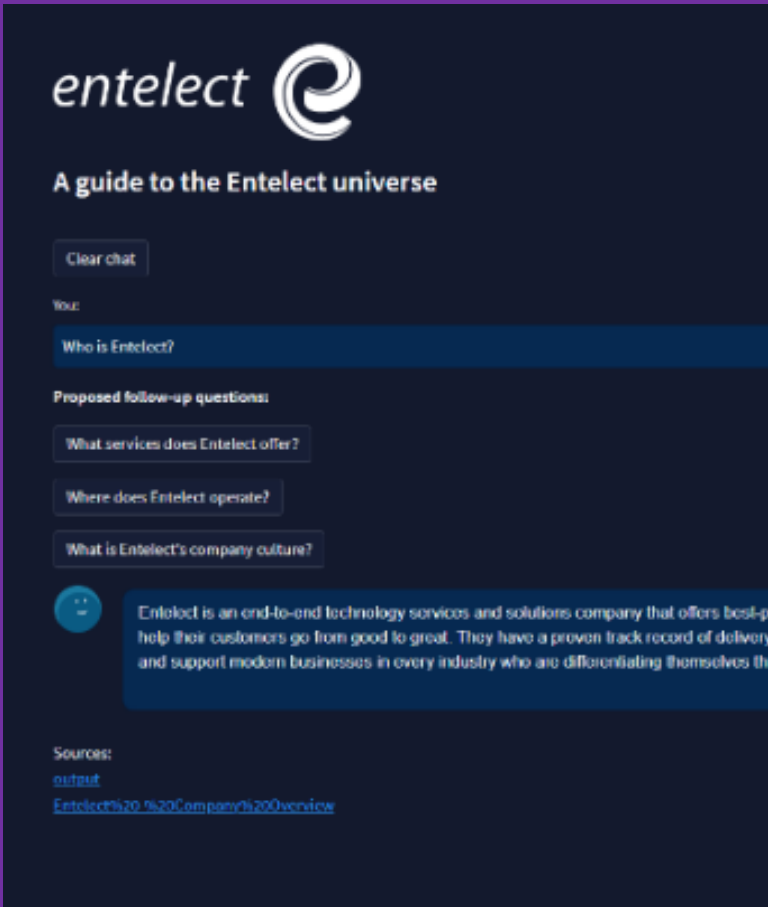

 **How we do
advanced
data solutions**

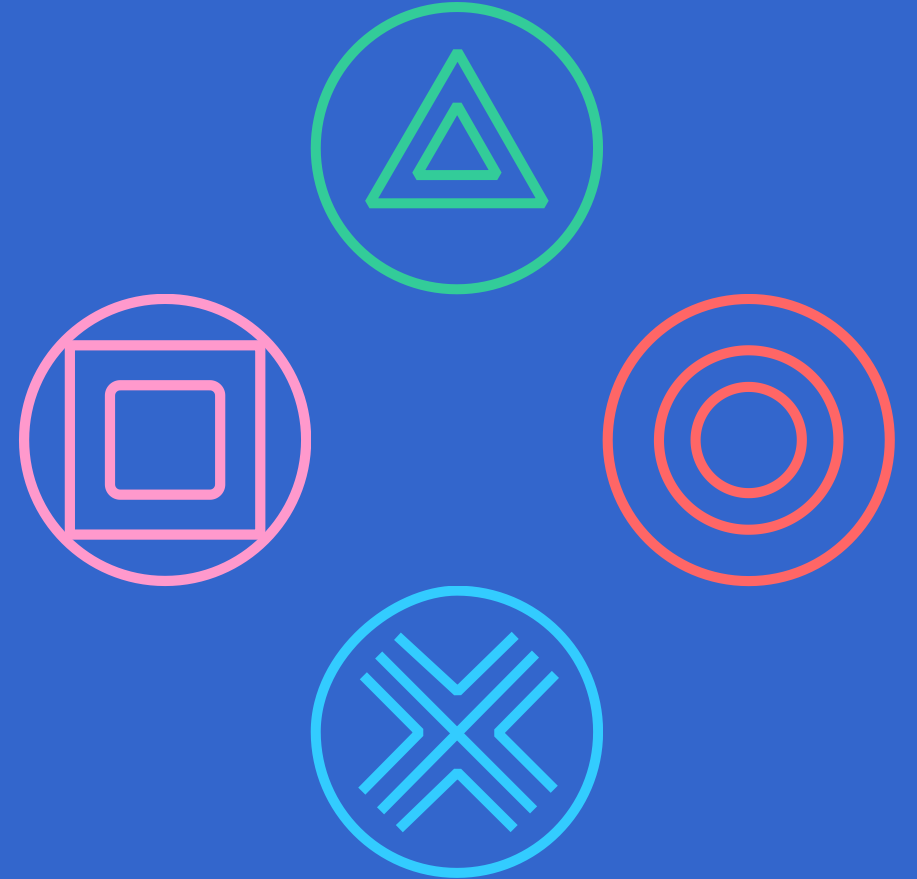

Advanced Data Solutions

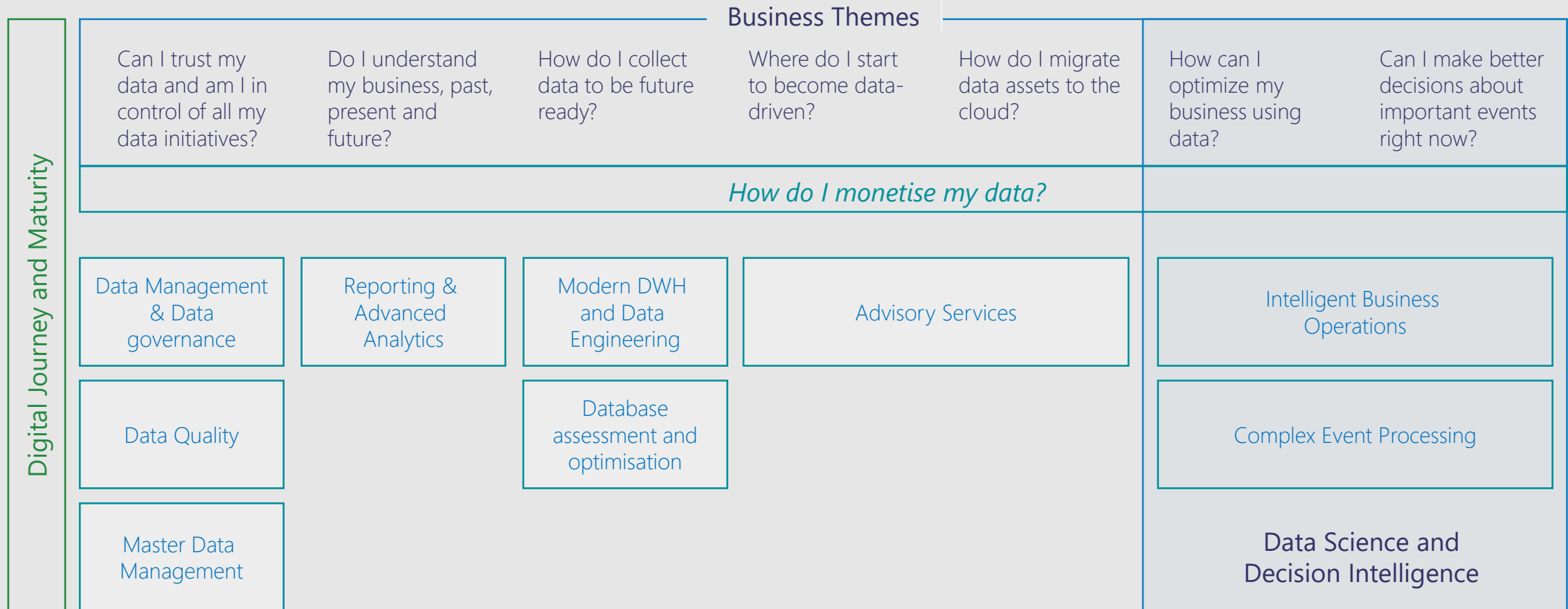

General ML Workflow

Get Data



Prepare Data



Model Creation



Test Model



Improve



Where is my model in the big picture?

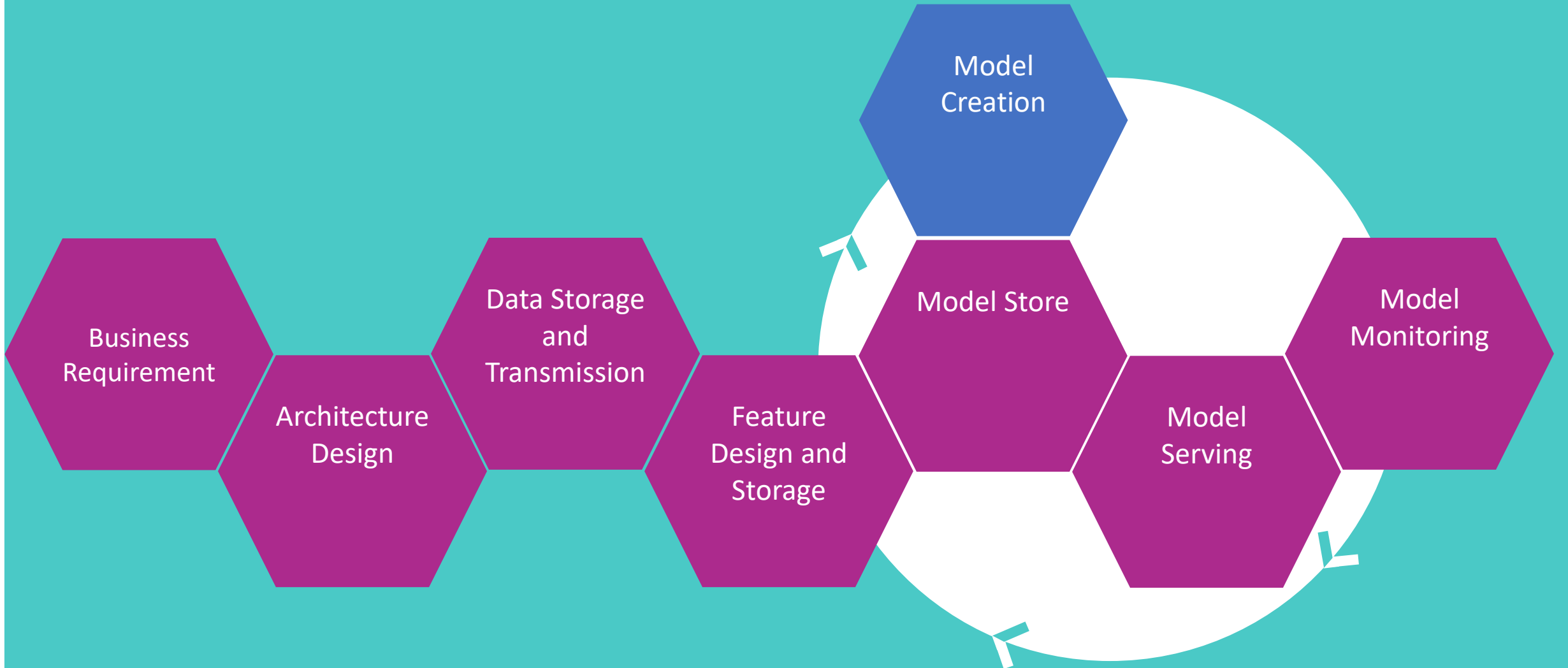

Cross-Industry Standard Process for Data Mining

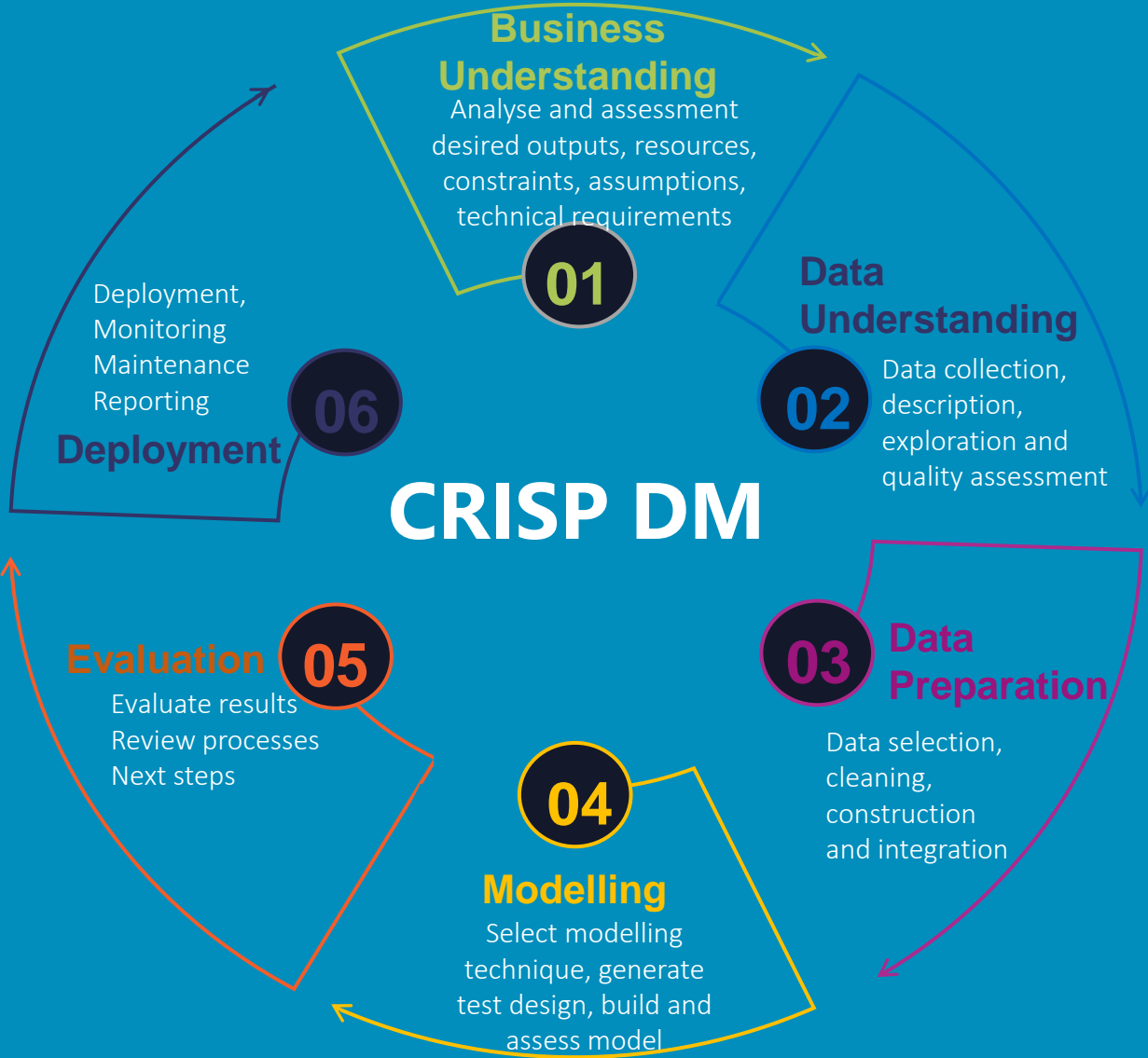

Breaking the system down

The C4 model for visualising software architecture
Context, Containers, Components, and Code

Breaking the system down

C4 Methodology

Level 1: Context

How the system fits into the world around it

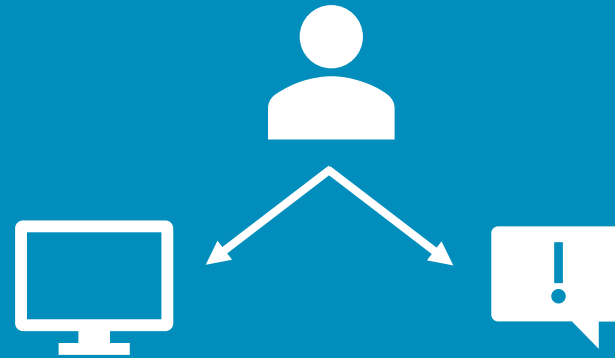

Breaking the system down

C4 Methodology

Level 2: Container

Software system in scope: high level technical building blocks

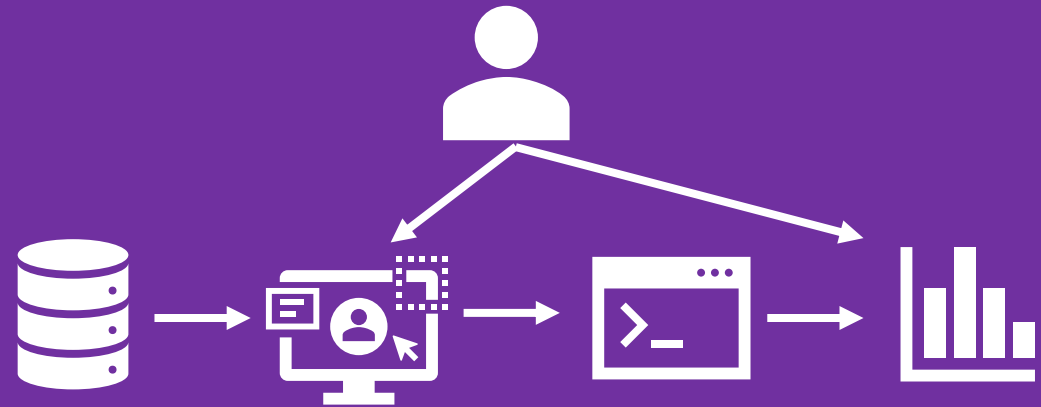

Breaking the system down

C4 Methodology

Level 3: Component

Breaks down the components in a container



Breaking the system down

C4 Methodology

Level 4: Code

UML Class Diagram – zoom in to individual component

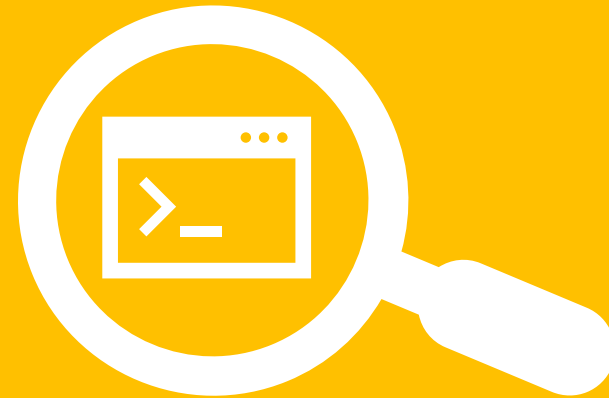



Hackathon Challenge

BLACK FRIDAY



100% OFF



Eskom

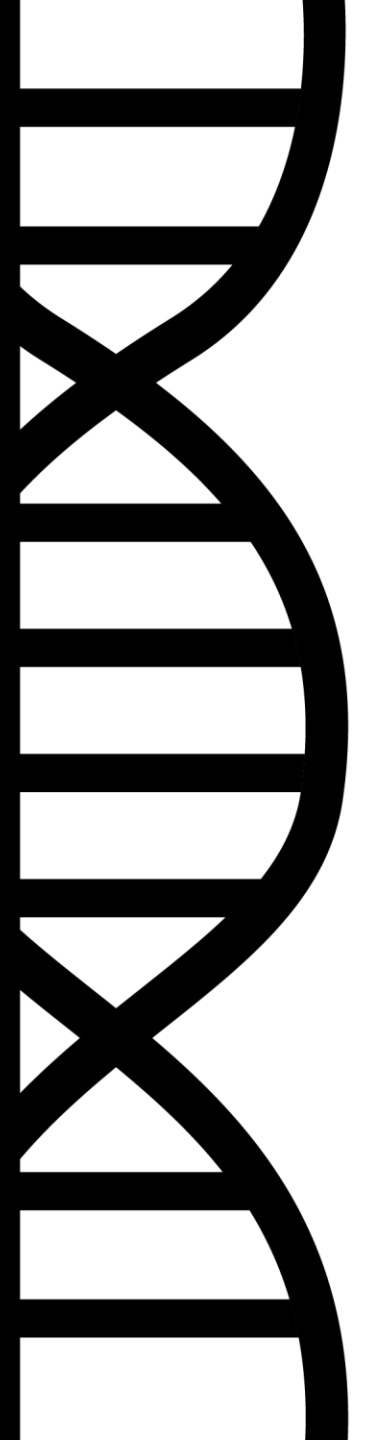

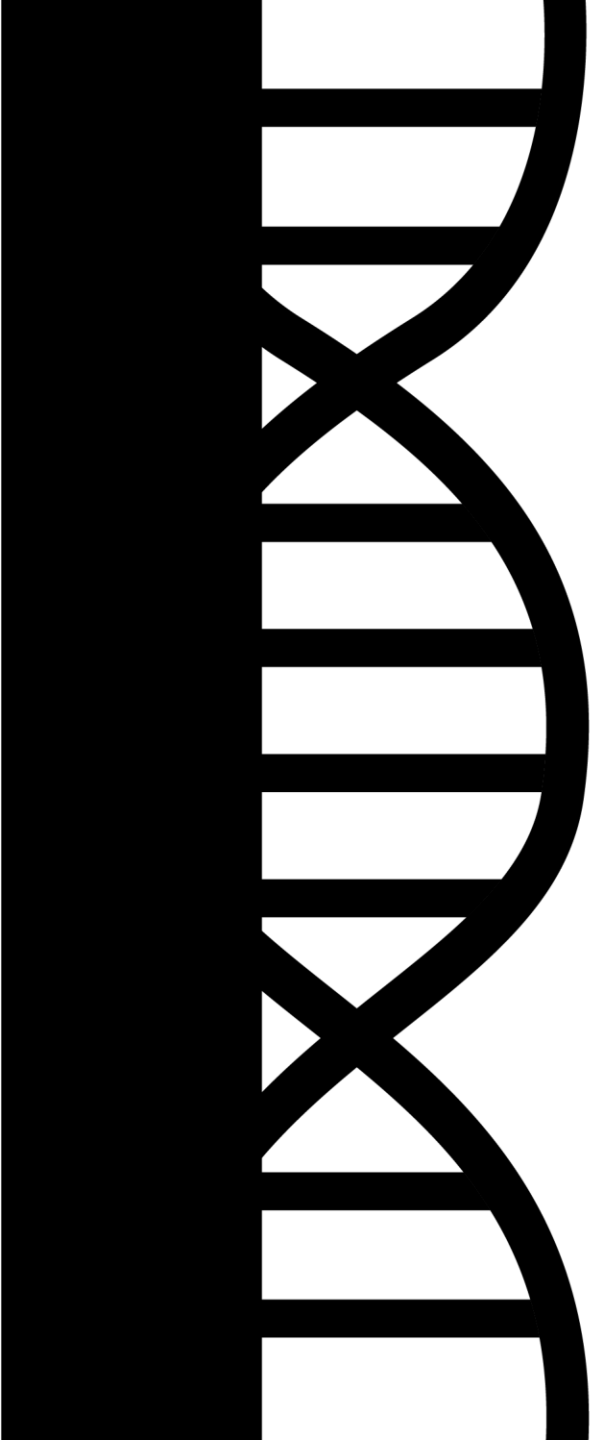

Topic?

- BE CREATIVE!

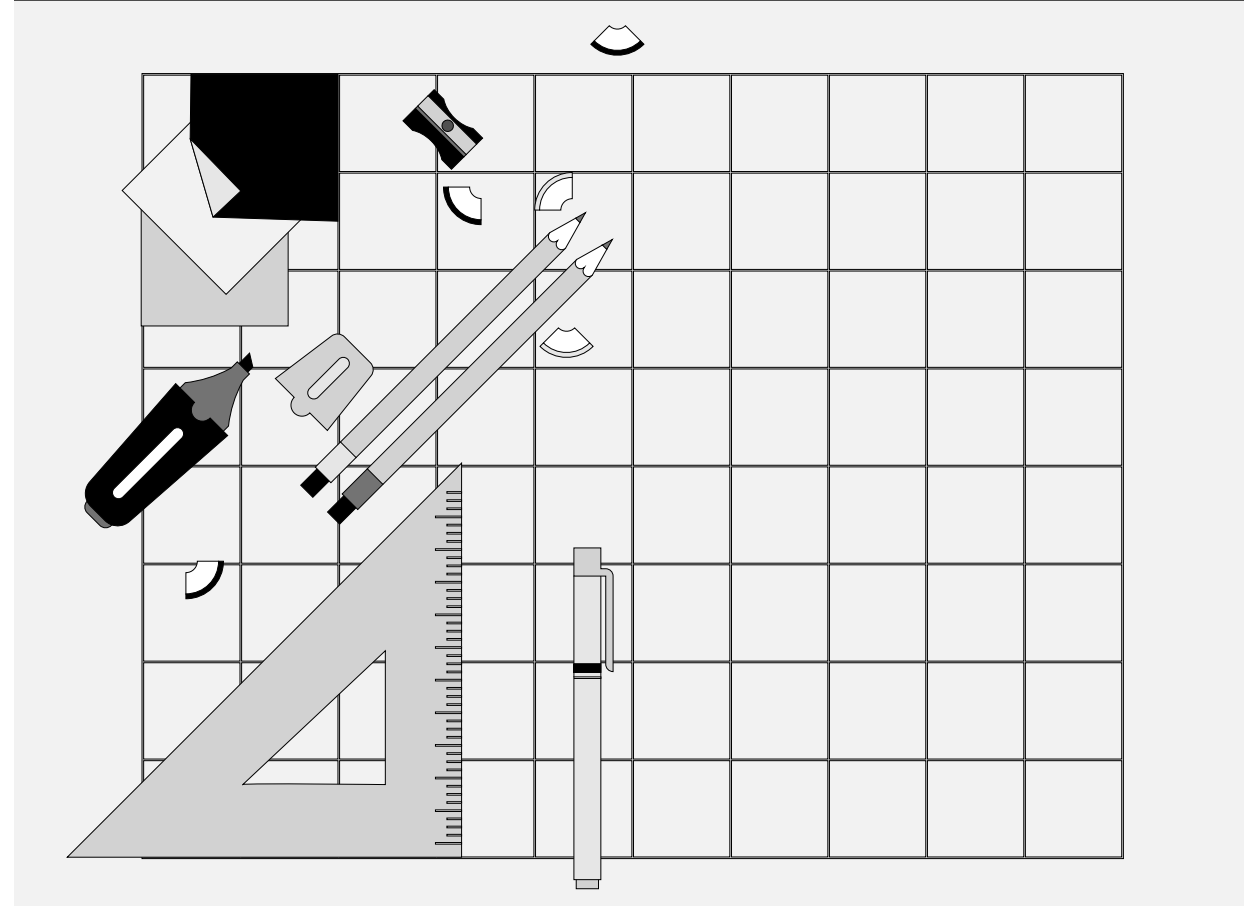

Proposed Schedule



Stage 1 – Problem Statement
- 20 mins

Choose a problem to solve



Stage 2 – Design - 1hr 40mins

Design a basic end-to-end solution



Stage 3 – Prototyping - 3 hrs

Rapid Prototype a model



Stage 4 – Pitch

3-minute Elevator pitch of the solution



Stage 5 - Assessment

Judging

Questions?

- GET HACKING!